



HALF RACK ASSEMBLY

Tools Required:

3/4" Standard Socket

3/8" Drive Ratchet

3/4" Combination End Wrench

HALF RACK ASSEMBLY INSTRUCTIONS

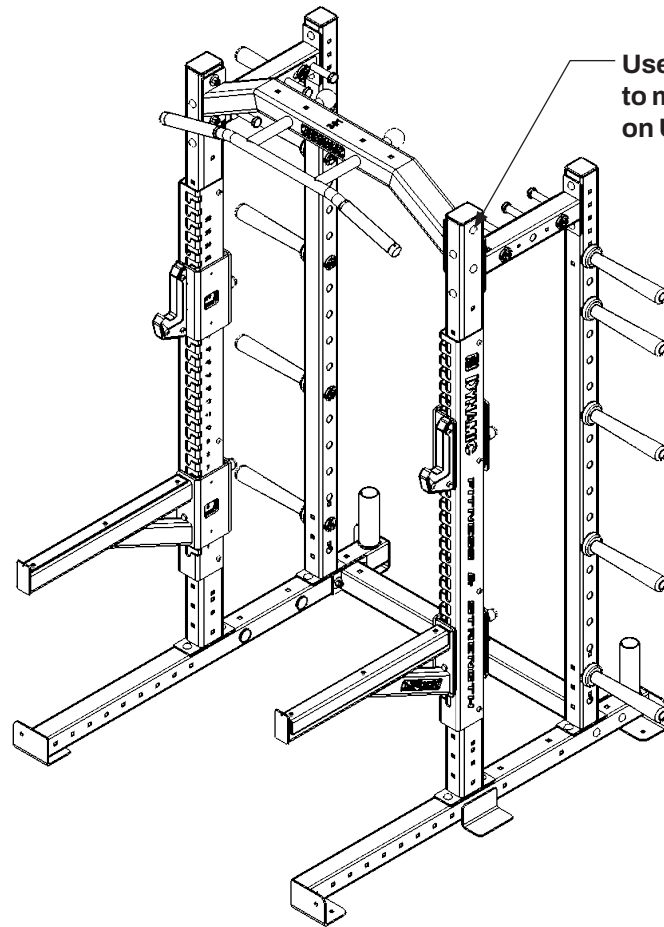

Use the 5" carriage bolts to mount chin station on ULTRA PRO® Models

ULTRA PRO®

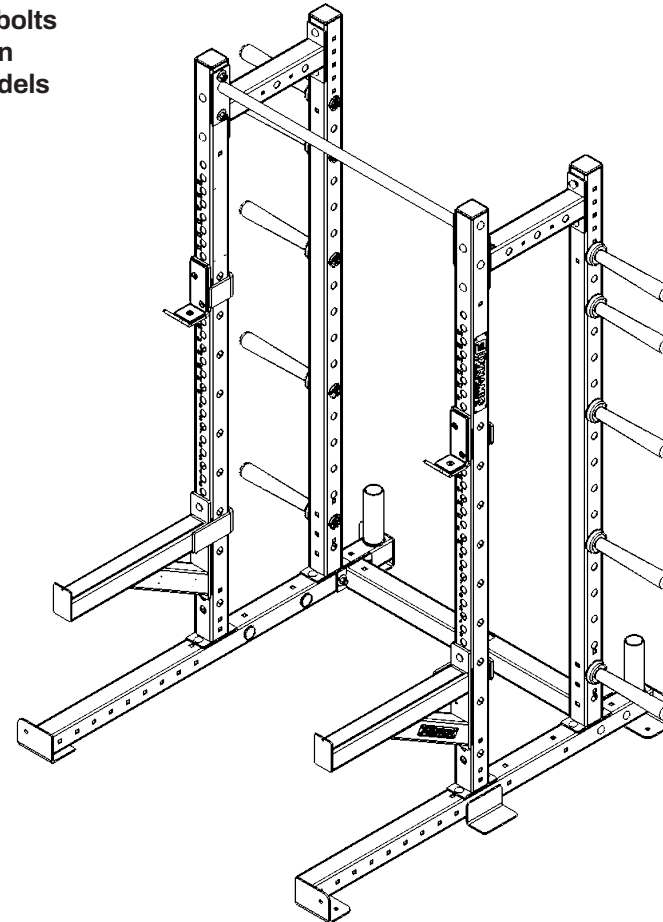

TITAN G2

Models:

- 400112
- 400112SB
- 400212
- 400212SB
- 700102
- 700102SB
- 700112
- 700112SB
- 700152
- 700202
- 700202SB
- 700212
- 700212SB

Before assembling this rack:

Consider how much space will be required around the unit to access weights and not interfere with other equipment.

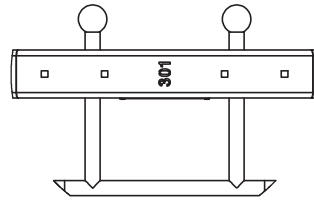
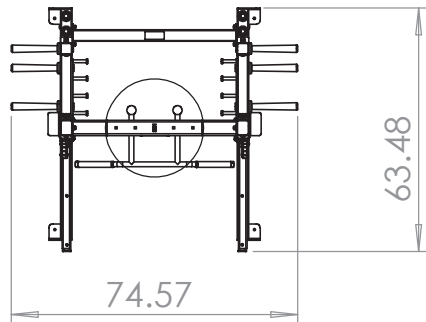

All parts have a part number. Position the part number to be covered by its mating component or up as shown in this view.

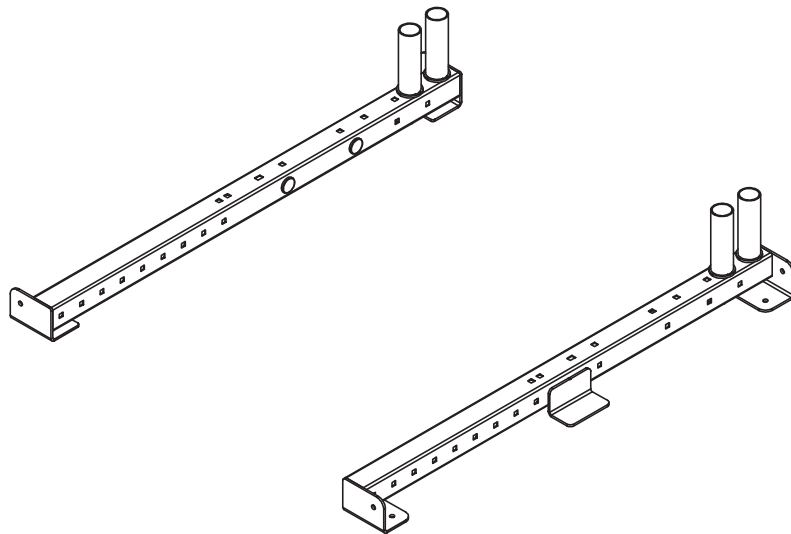

Step 1

Attach bar holders to ends of each base as shown. Depending on the build of your rack the bar holder number may vary. (Max two per side)

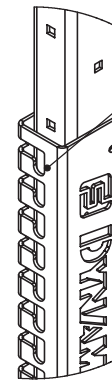

The mounting access for bar catch and safety must be to inside of rack as shown.
Note: Titan G2 Series will not have an upright wrap as shown

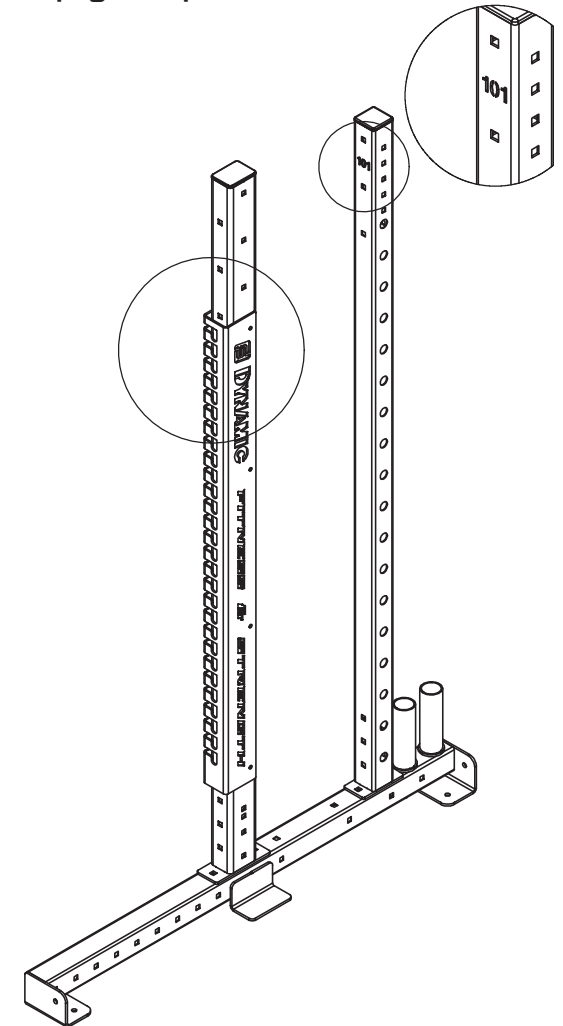

Step 2

Attach storage post and front upright to right base as shown. Repeat for left side.

Note: The base mounting flanges must face outward

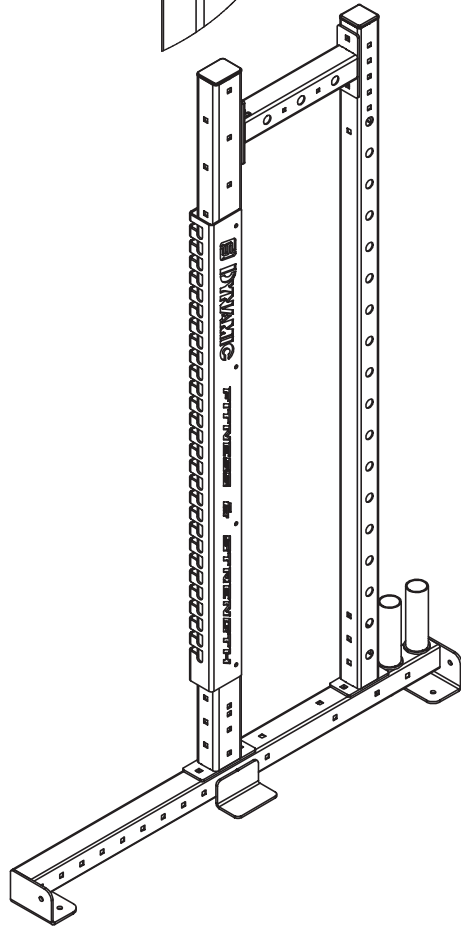
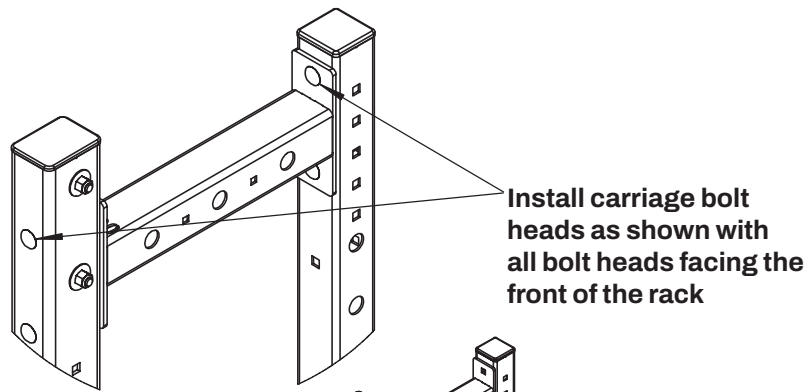

Step 3 A

Attach horizontal cross member to storage post and front 8' upright to right base as shown. Repeat for left side.

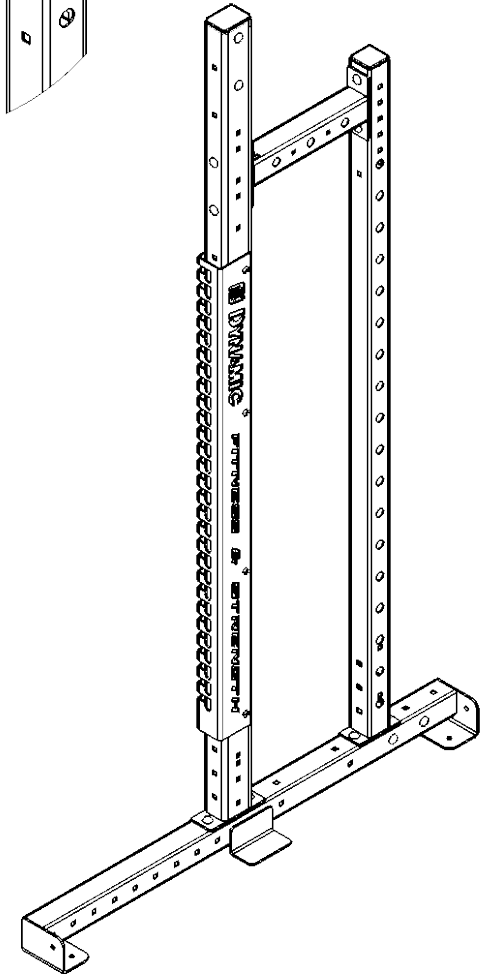
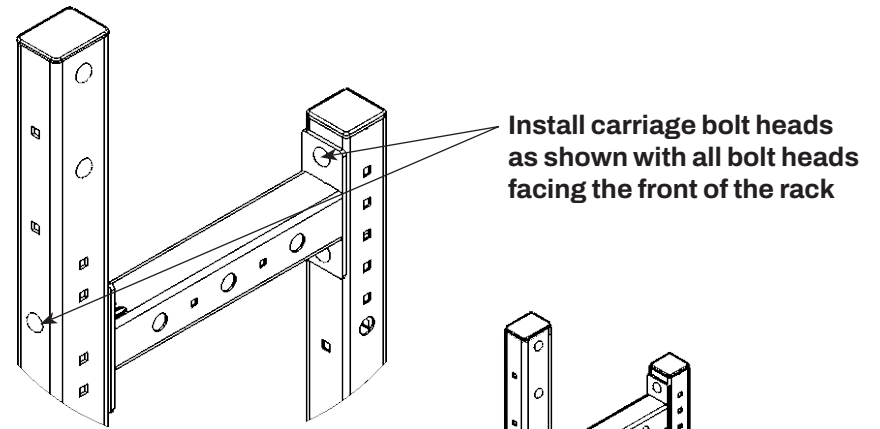

Step 3 B

Attach horizontal cross member to storage post and front 9' upright to right base as shown. Repeat for left side.

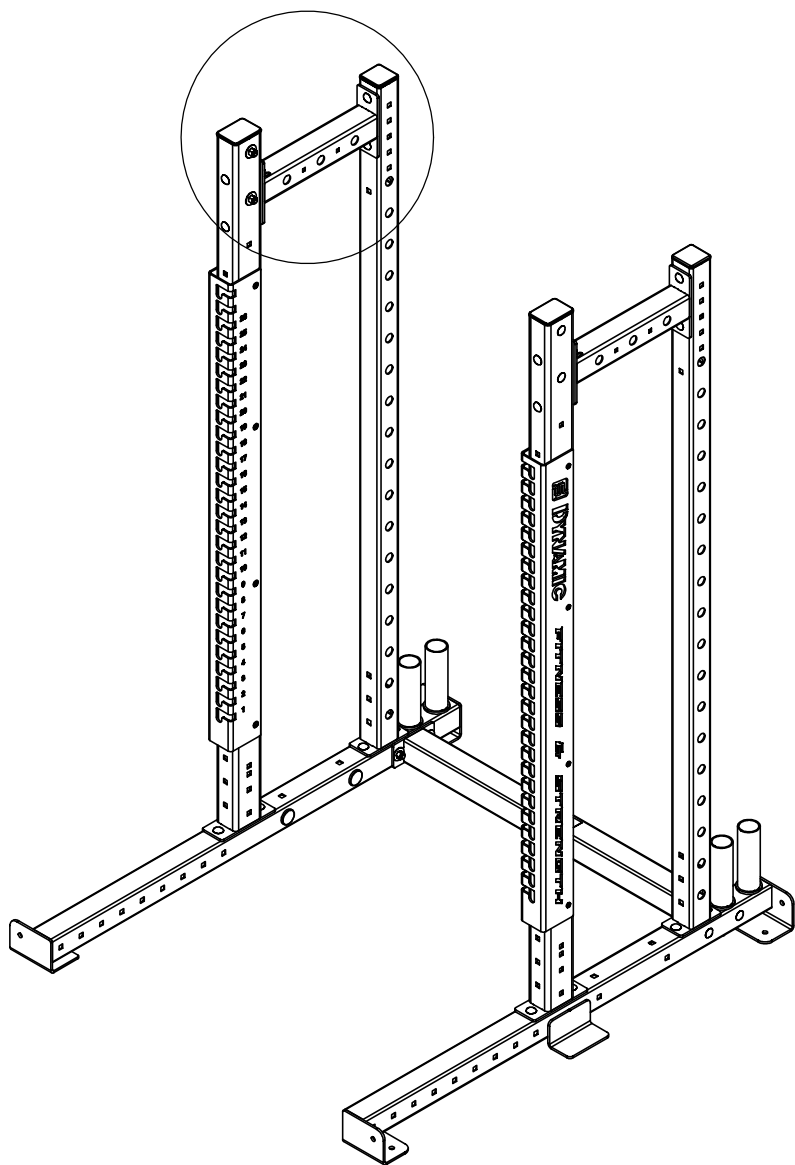

Step 4

Attach right half to left half as shown using horizontal base.

Note: The carriage bolt heads should be on the outside of the rack.

Use 5" bolt on ULTRA PRO®
Use 4" bolt on TITAN G2

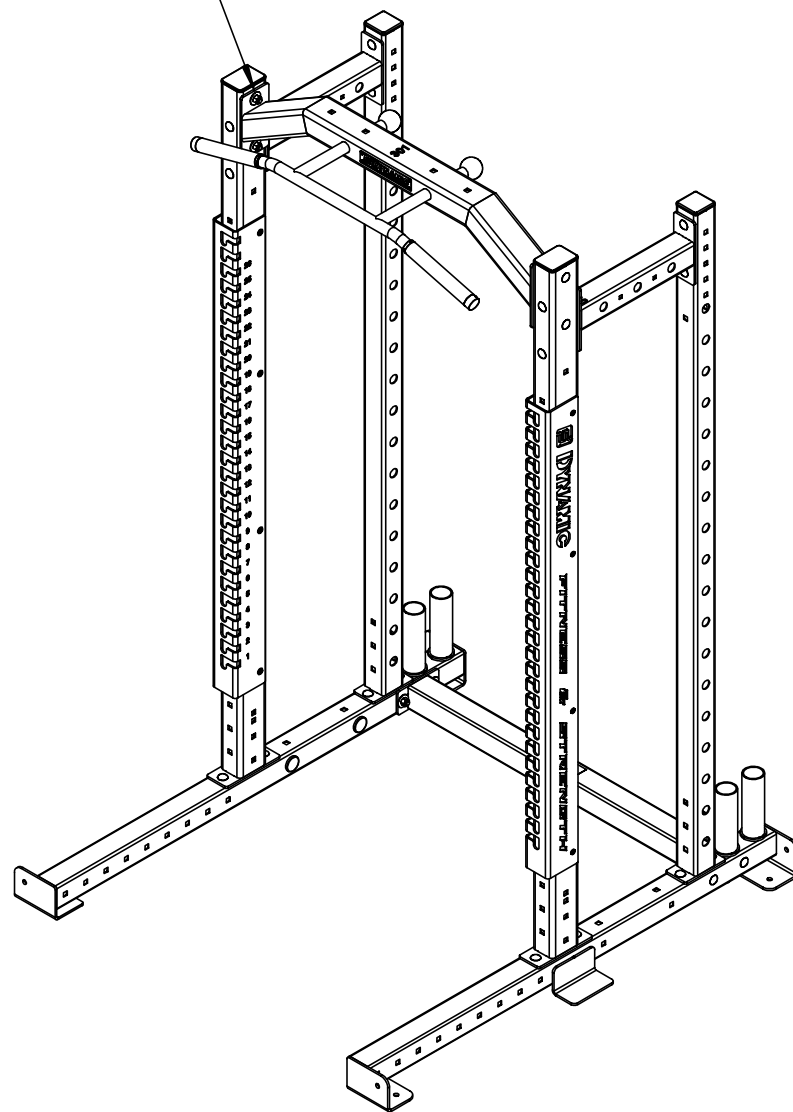

Step 5 A

Attach horizontal chin up bar between left and right 8' uprights as shown. This bar may vary based on your model.

Note: This step requires two people to lift and fasten.

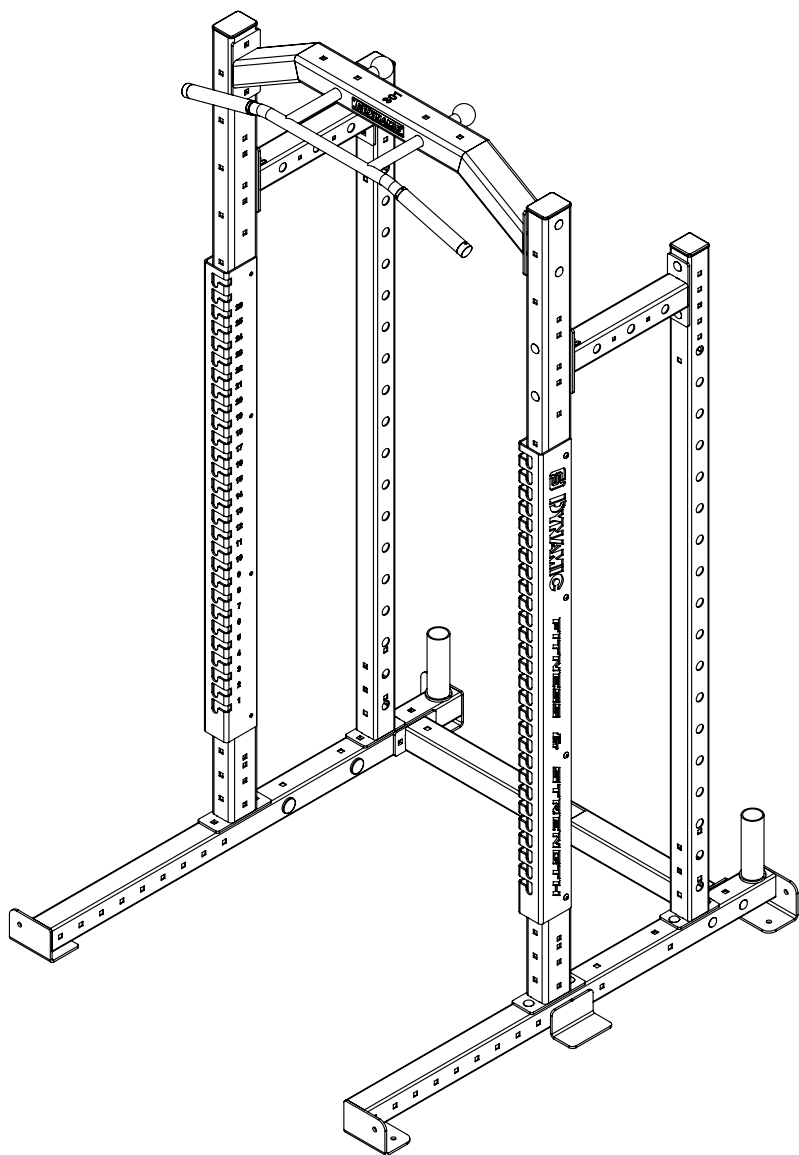

Step 5 B

Attach horizontal chin up bar between left and right 9' uprights as shown. This bar may vary based on your model.

Note: This step requires two people to lift and fasten.

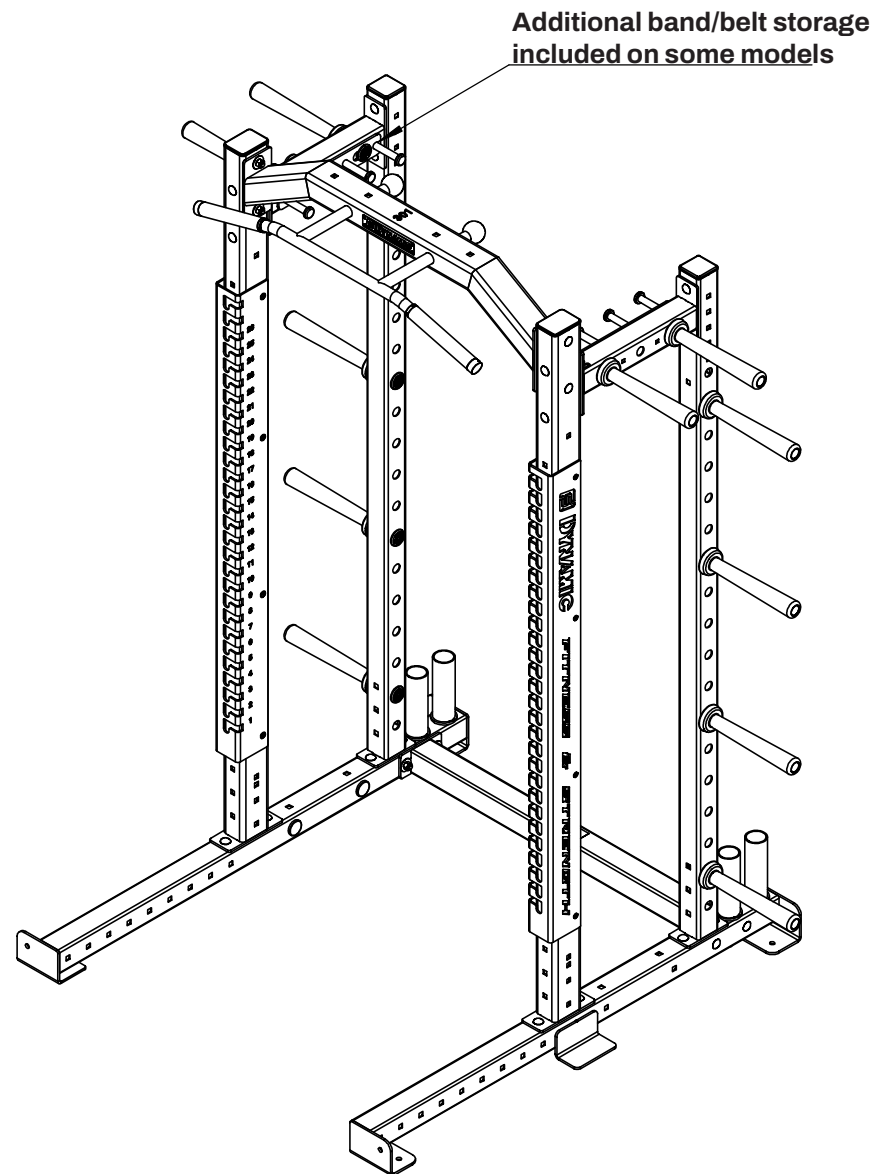

Step 6

Mount weight pegs in desired locations. The recommended spacing between each peg is (4) holes as shown.

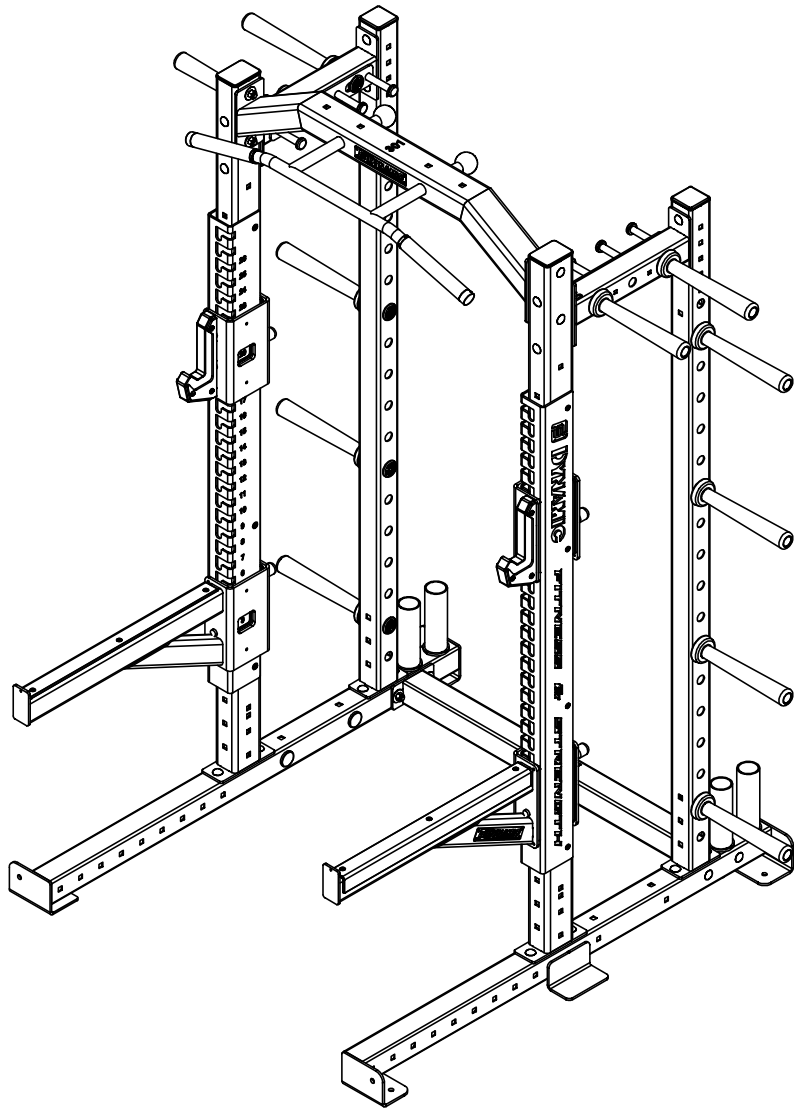

Step 7

Mount bar catch and safety assemblies to rack at desired location.

Mount with 1/2" floor anchors at all four corners using holes provided. (Anchors not provided)

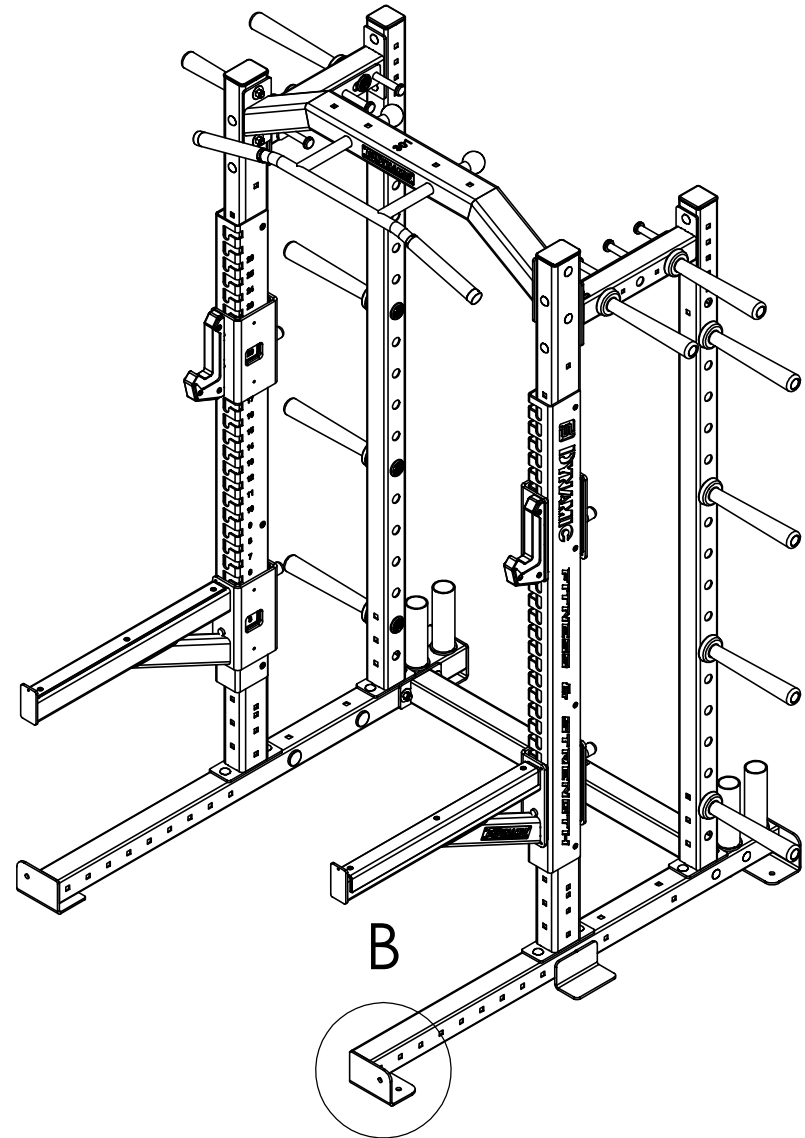

Step 8

Position rack in final position and anchor to floor using available holes on each base.

End of bolt **MUST**
extend beyond nut face
at all locations

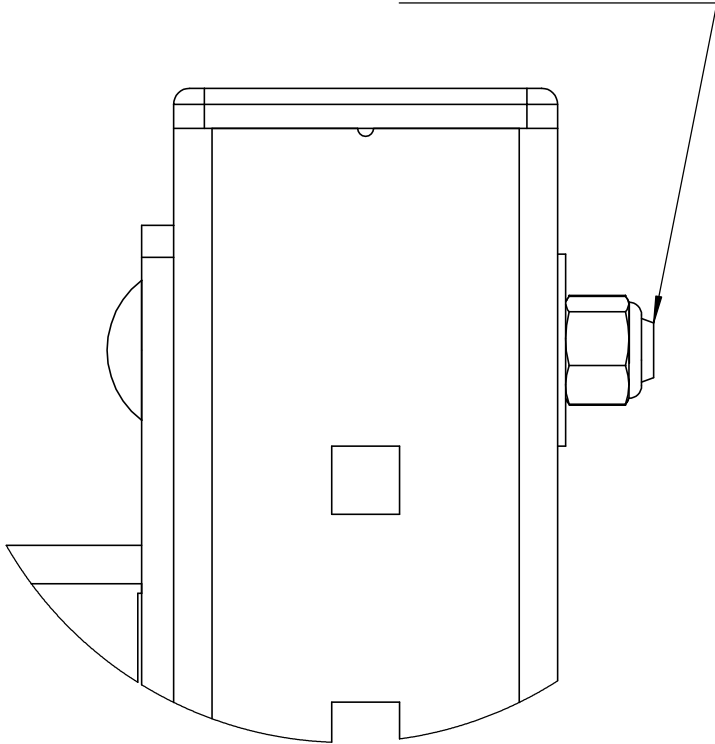

Step 9

Tighten each hardware connection.
The end of each bolt should extend beyond nylock nut
face as shown.

Maintenance

**Preventative actions will keep your
facility safe and productive for all
users**

- 1) Wipe Down Equipment
Use general purpose cleaner.
Avoid Bleach based solutions.
- 2) Lubricate All Moving Parts
Use a silicone spray and clean
rag to apply.
- 3) Tighten All Hardware
Inspect the condition of all
hardware and tighten loose
fasteners.
- 4) Inspect Wear Guards
To prevent metal to metal
contact with components keep
wear surfaces protected.
- 5) Replace All Worn Parts

HARDWARE PACK CONTENTS
QUANTITIES VARY BY MODEL

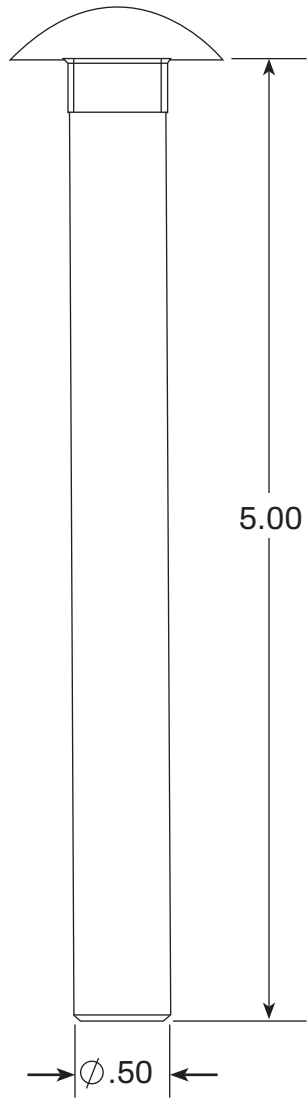

CAIR-500-002

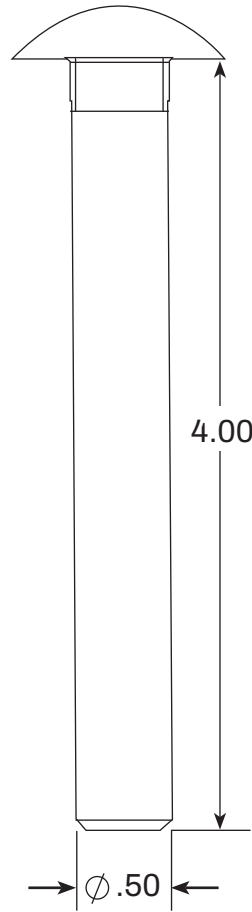

CAIR-500-001

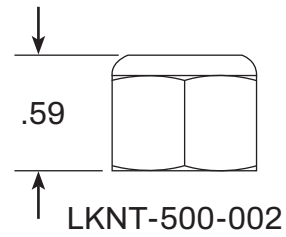

LKNT-500-002

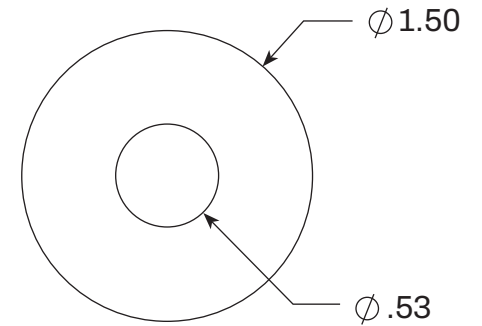

FLW-500-001

Tools Required:

(2) 1/2" Hex Key Wrench

TITAN PRO HALF RACK ASSEMBLY INSTRUCTIONS

Models:

400512

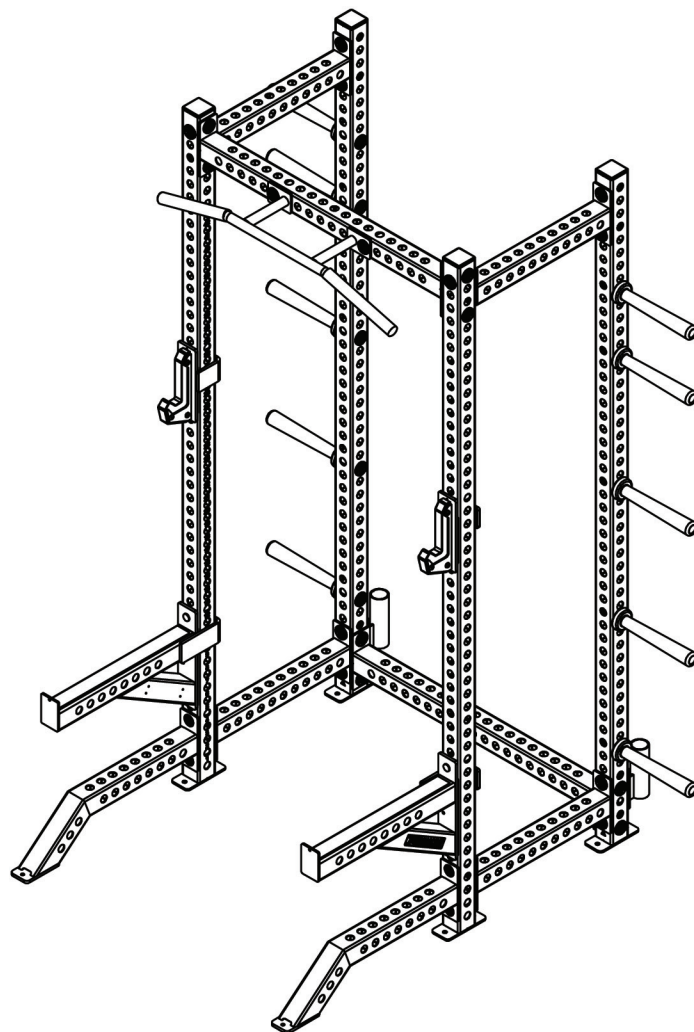

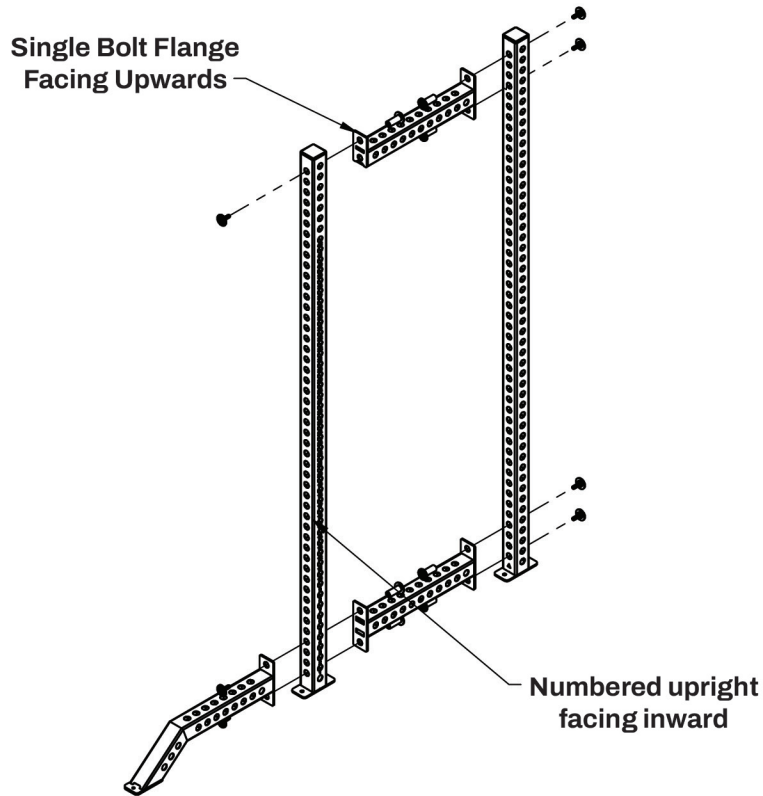

Step 1

Install the upright with laser cut number, and rear non numbered upright together using the shown 24" connectors. The lower 24" connector will have 2 bolt flanges on both ends, and the upper connector will have a single bolt flange on one end. The single bolt flange will connect to the numbered uprights with the flange facing upwards as shown. Repeat step to create 2 side frames.

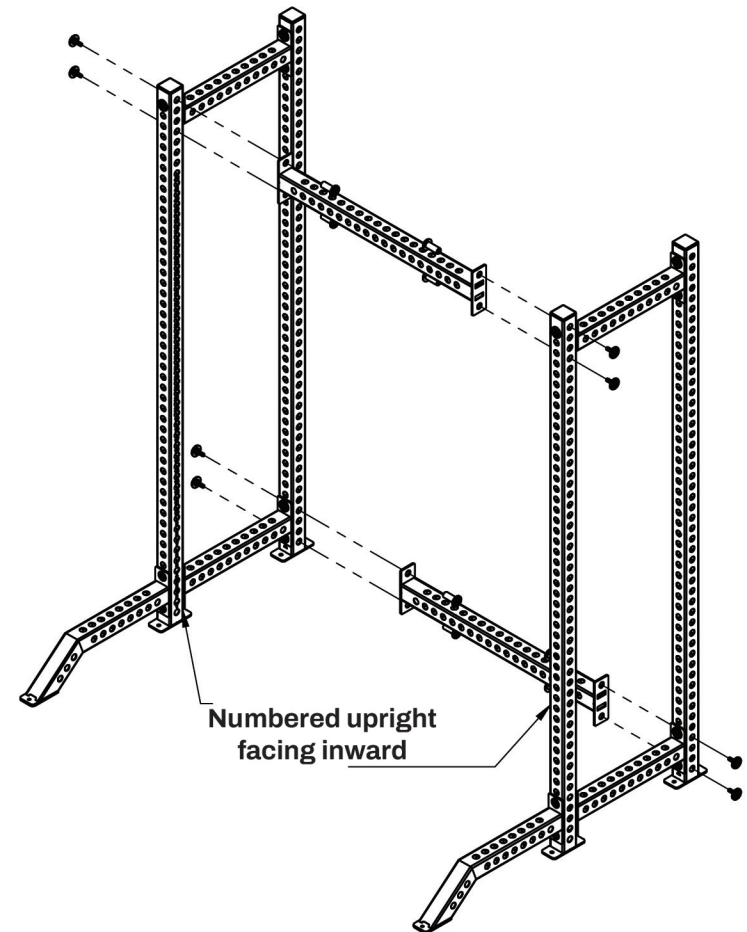

Step 2

Take 2 side frames from step one, making sure that both numbered sides are facing inward, and join together using 2-43" connectors. Connect using the lowest possible holes on the rear non numbered upright, and the highest 2 possible holes on the numbered uprights.

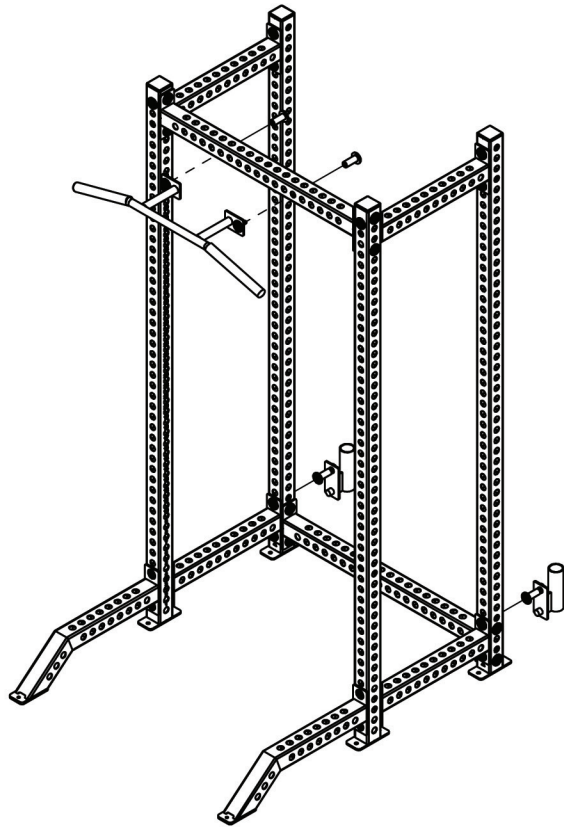

Step 3

Install chin up bar onto center of the upper front connector as shown.

Install 2 bar holders at desired location, standard mounting location is shown.

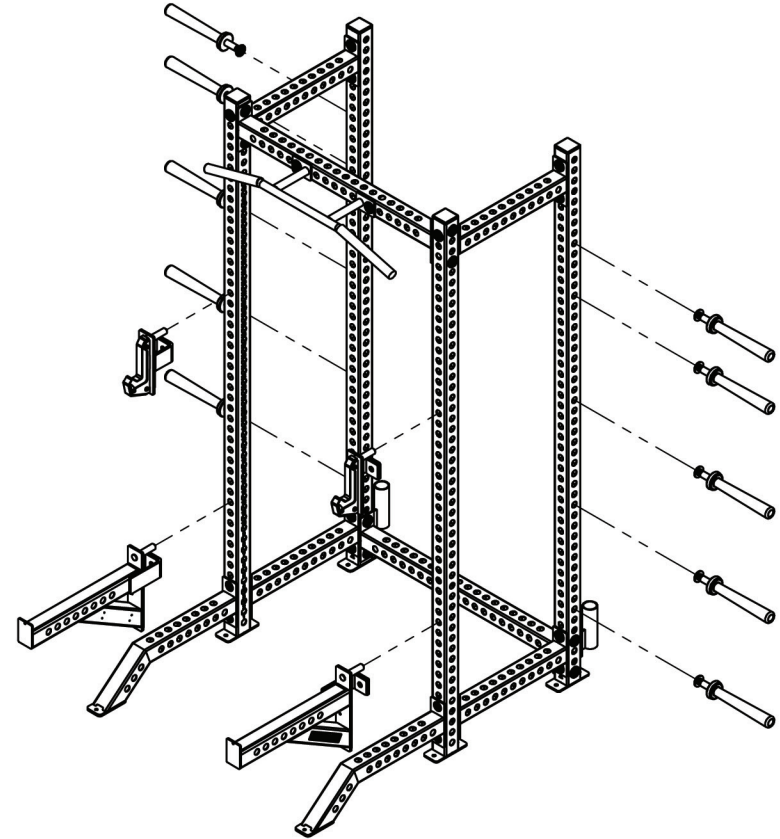

Step 4

Install safeties, J-cups and weight pegs at the desired location. Standard configuration shown.

Double check all hardware is tightened before use.