



ANNEX STORAGE ASSEMBLY

Tools Required:

3/4" Socket
3/4" Wrench
4" Socket Ext
1/2" Hex Keywrench (2)

ANNEX STORAGE

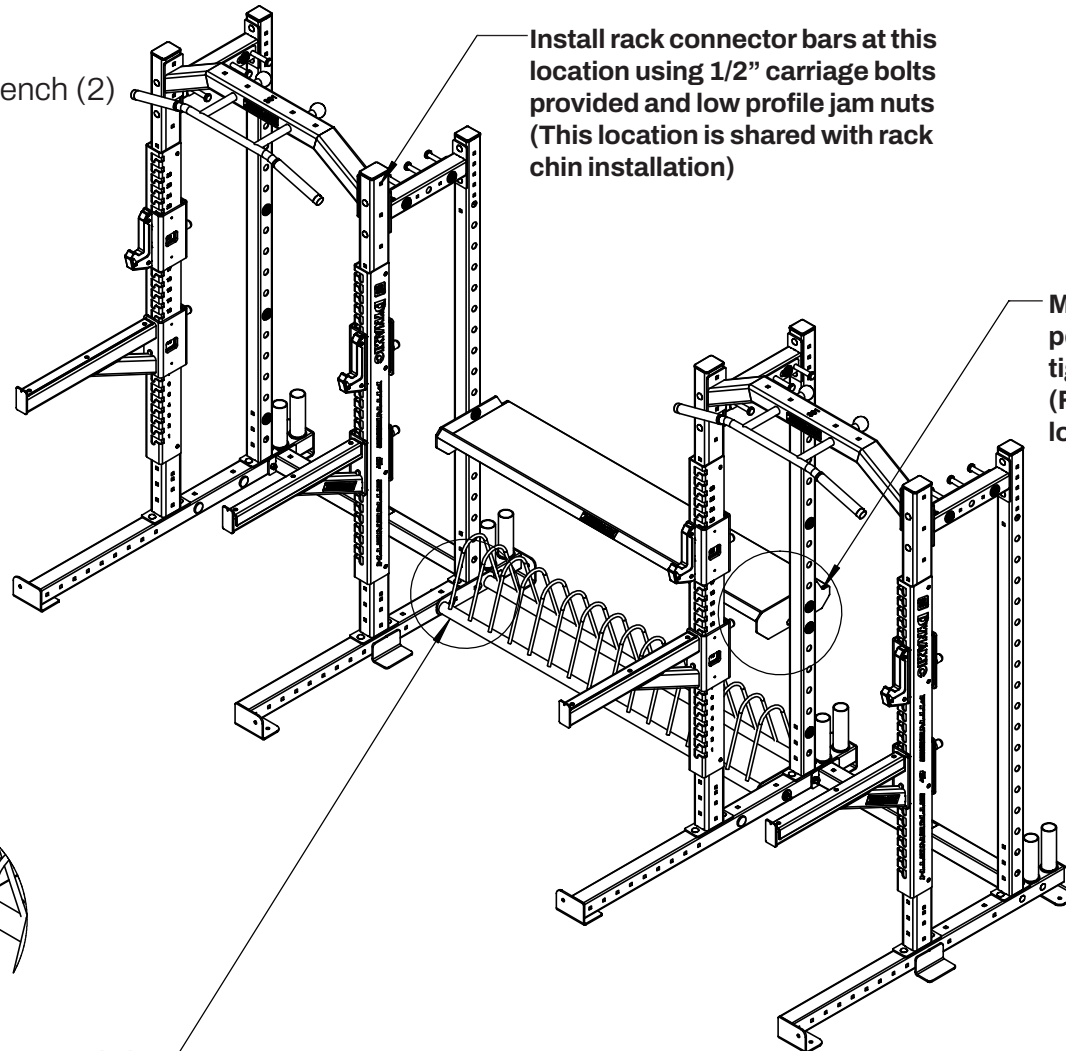

Install rack connector bars at this location using 1/2" carriage bolts provided and low profile jam nuts (This location is shared with rack chin installation)

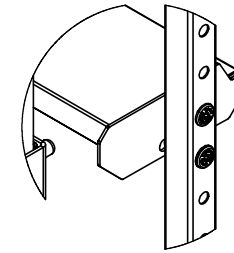

Mounts to existing storage posts at weight peg locations. Set to desired height and tighten with 1" mating bolts, tools provided. (For dumbbell setting, use second set of lower holes to place shelf at an angle.)

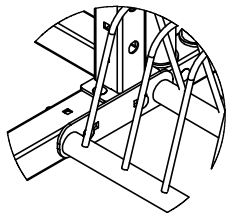

Bumper storage mounts to base using 1/2" hardware provided. Remove plastic cap, and install provided short carriage bolt at this location. Second mounting location shares center cross bar bolt.

- 1) Assemble all racks and space racks approximately 43", 60.5", 71", 95" apart, which is dependent on your shelf size.
- 2) Confirm desired shelf positions
- 3) Loosely install all shelves
- 4) As required - install rack logo connector bars at top location on front uprights
- 5) Tighten all hardware
- 6) Mount weight pegs on outside storage posts at desired location

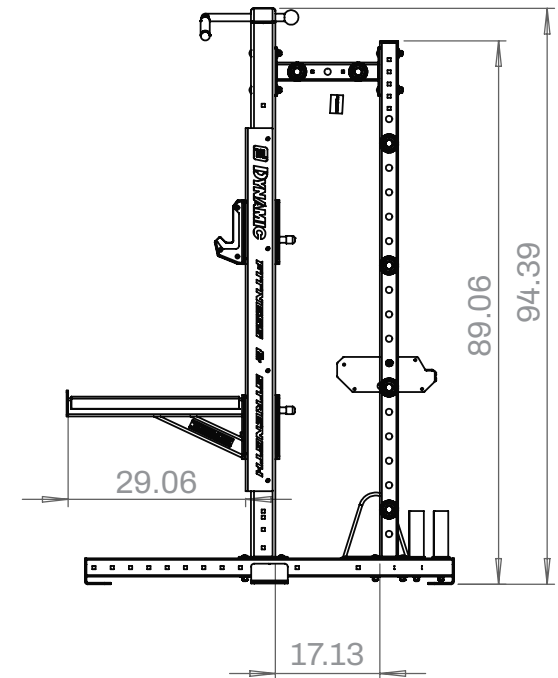
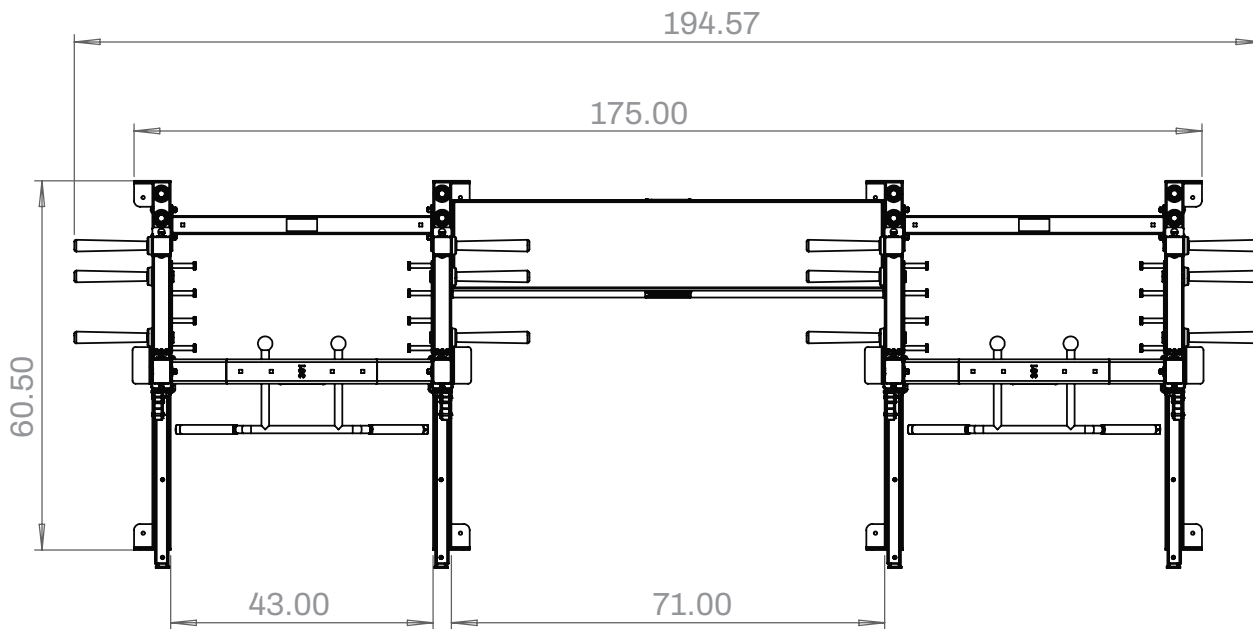

For installation and assembly questions, please contact customer service at 844-678-7447.
See the complete line of products at MYDYNAMICFITNESS.COM

