

# BRIDGE ASSEMBLY

**Tools Required:**

- 3/4" Wrench or Socket
- 5/32" Hex Key Wrench
- 7/16" Wrench or Socket
- 9/16" Wrench or Socket

**BRIDGE ASSEMBLY INSTRUCTIONS**

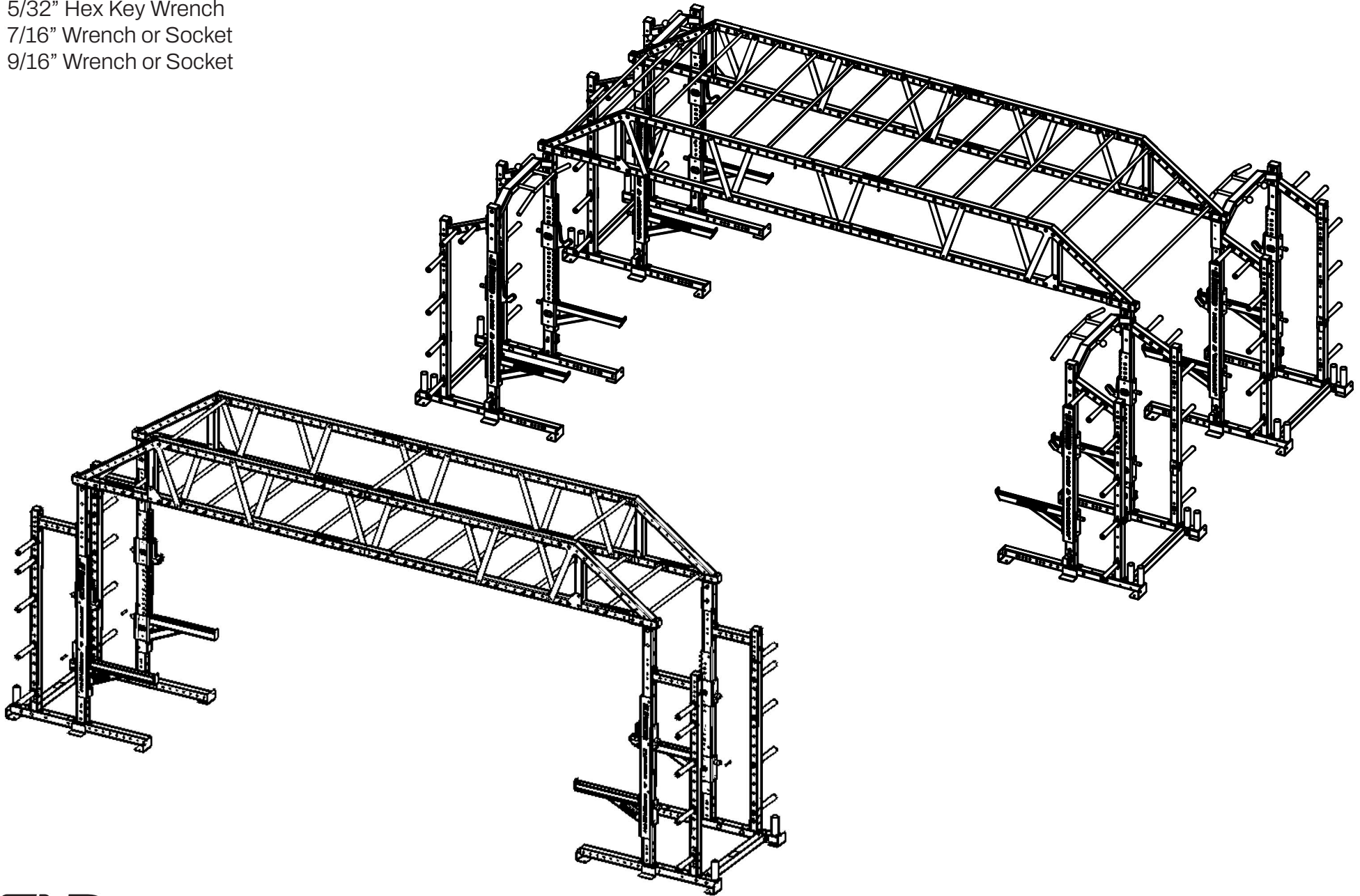

### INSTALLED BRACKETS

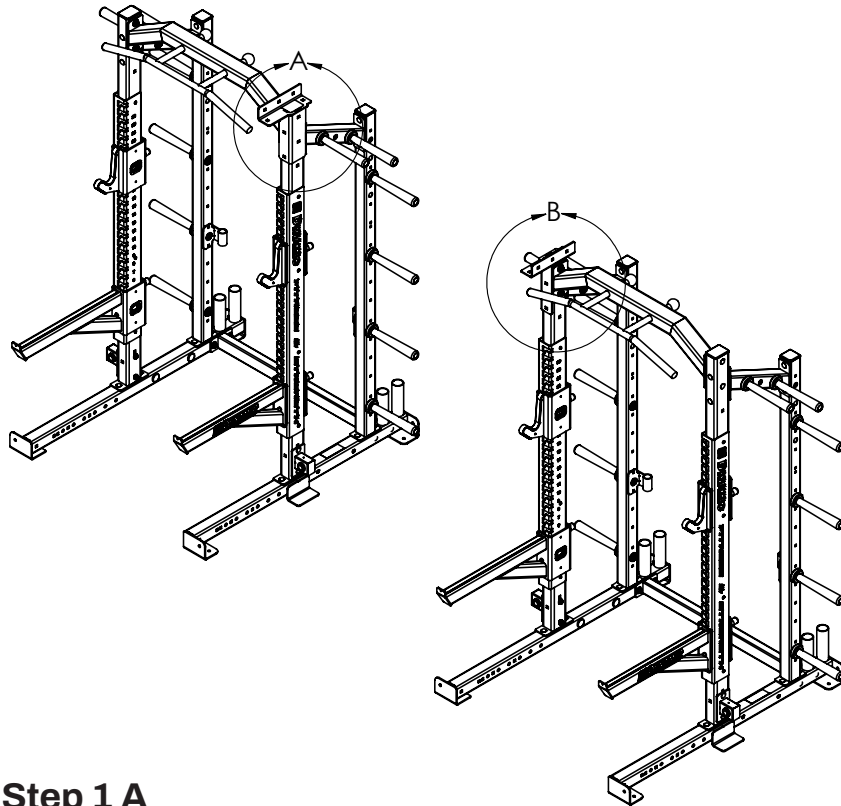
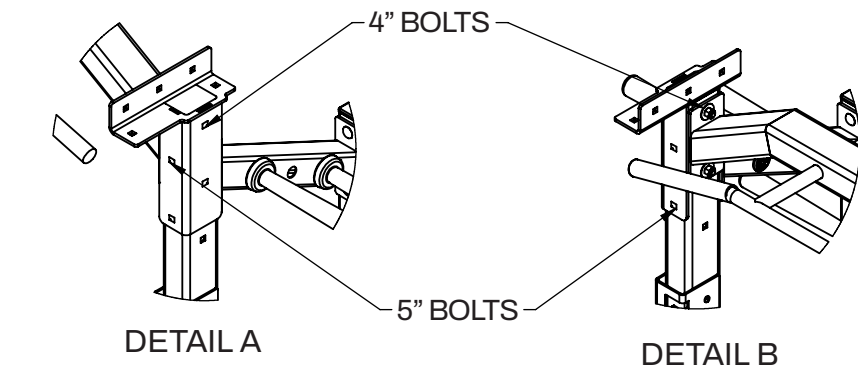

#### Step 1 A

Install bridge mounting brackets onto each corner of the 4 racks that will be bridged together. Bolt brackets into place as shown using with bent lip of bracket facing towards chin up bar. Secure using supplied 1/2" x 4", 1/2" x 5" bolts, washers and jam nuts.

### INSTALLED BRACKETS

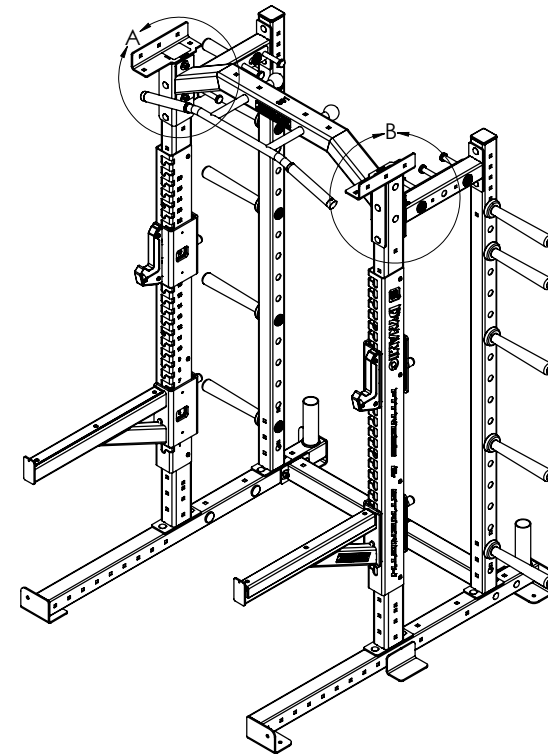
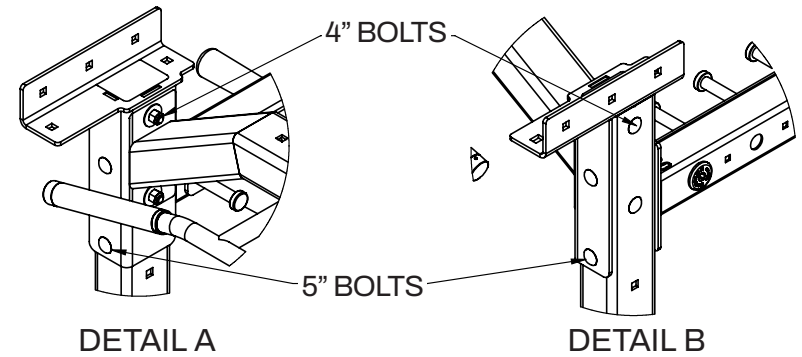

#### Step 1 B

Install bridge mounting brackets onto each corner of the 4 racks that will be bridged together. Bolt brackets into place as shown using with bent lip of bracket facing away from the chin up bar. Secure using supplied 1/2" x 4", 1/2" x 5" bolts, washers and jam nuts.

**Step 2 A**

Lay out pieces the side frame on the floor as shown. Insert (4x) connection tubes into end frames and center connecting tubes as shown in Detail A.

**Step 2 B**

Lay out pieces the side frame on the floor as shown. Insert (2x) connection tubes into end frames as shown in Detail B.

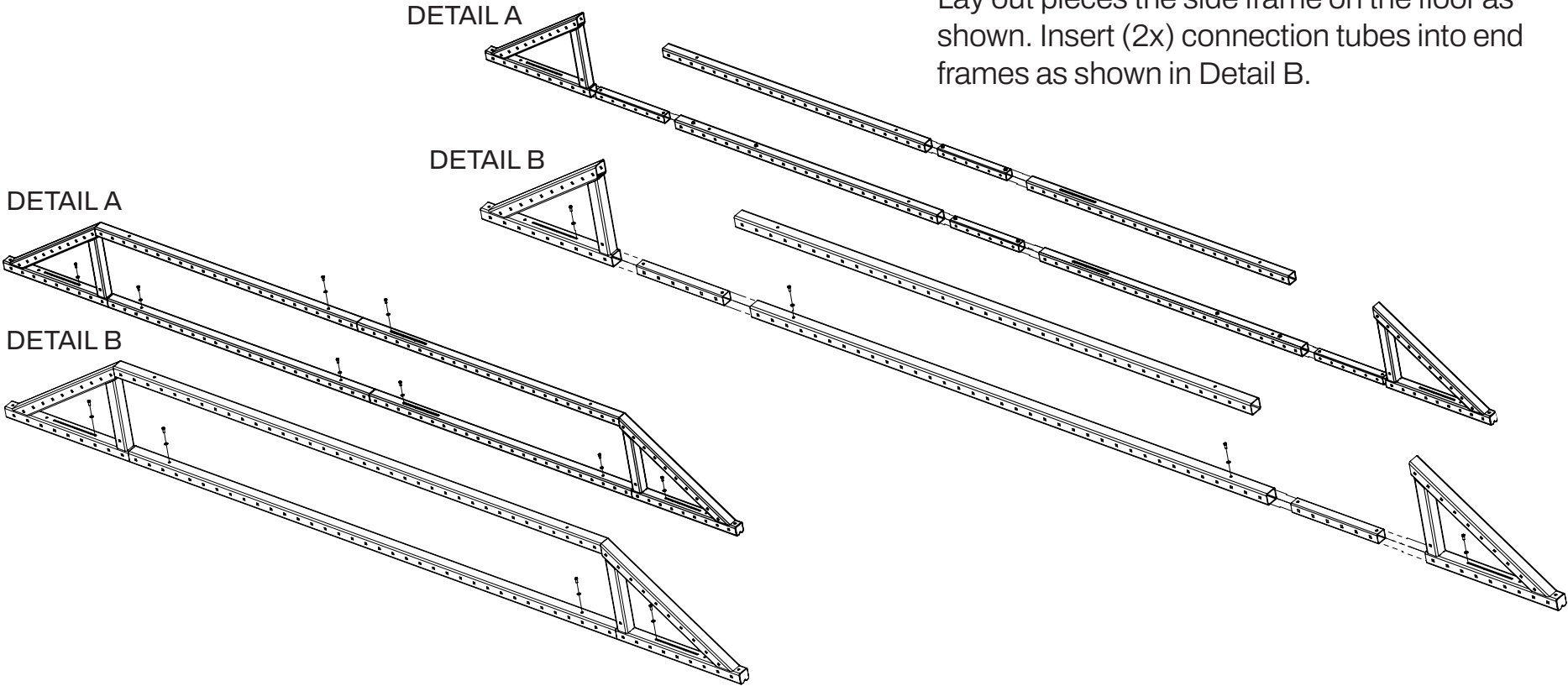

**Step A**

Slide frame pieces together, aligning the holes of the connecting tubes with the holes on the end frames and cross tubes. Once aligned secure frames into place using 3/8" x 1" bolts and washer. Repeat for opposite side. Center bolts may be required depending on the model. See image Detail A for reference.

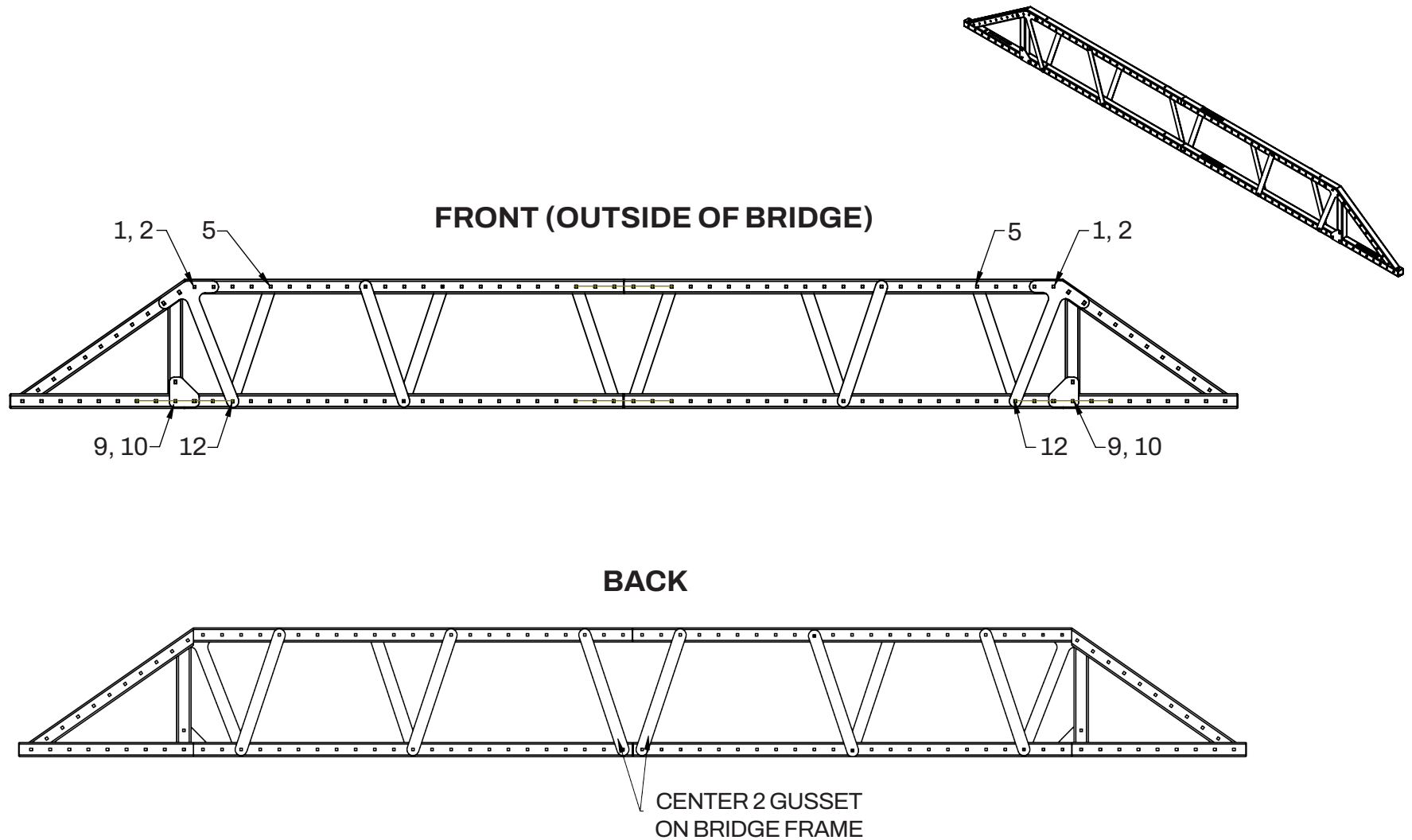

#### Step 4

Install corner brackets, angled gussets and 2 center gussets. Layout and evenly space all remaining gussets between center and outer gussets. Spacing will vary by model. Do not fully tighten bolts. Repeat for opposite side.

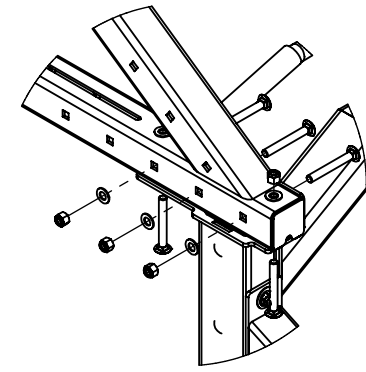
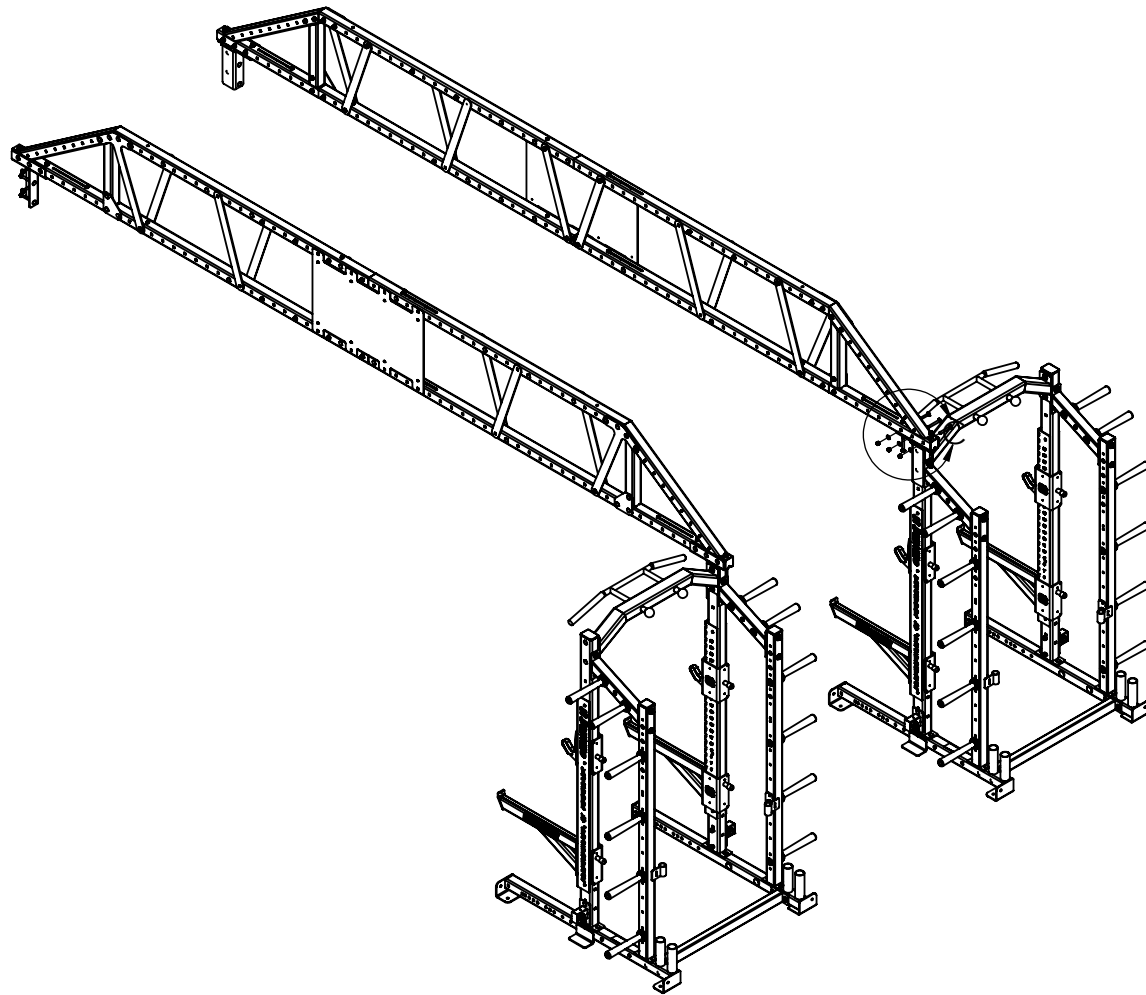

DETAIL C

**Step 5**

Install sides of bridge system onto brackets mounted to rack from step 1. Once the sides are lined up, secure using (5x) 1/2" x 4" bolts per bracket as shown in DETAIL C.

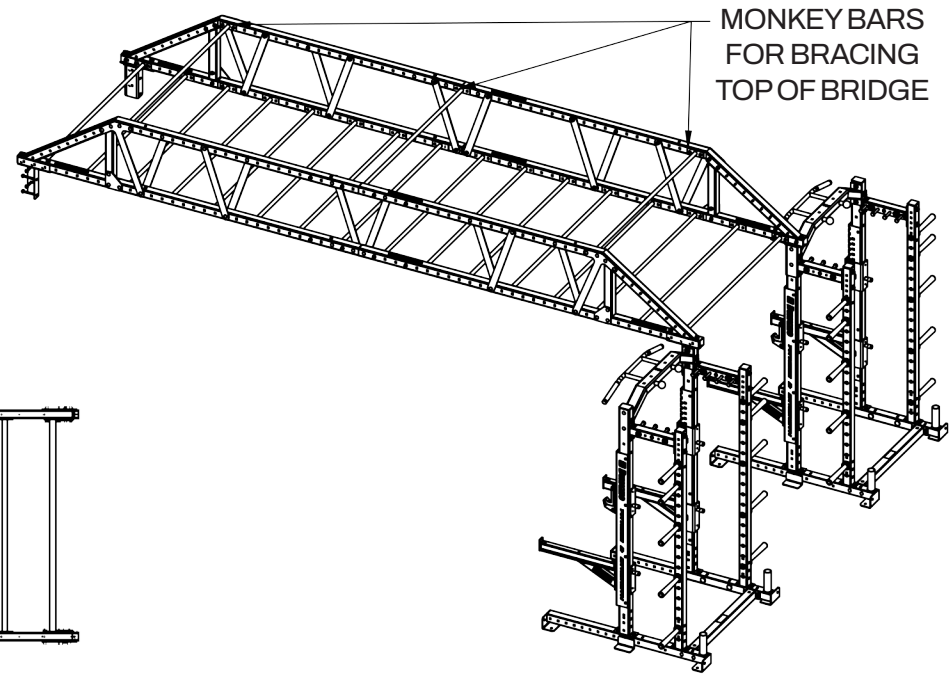
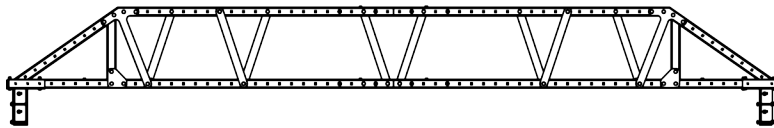
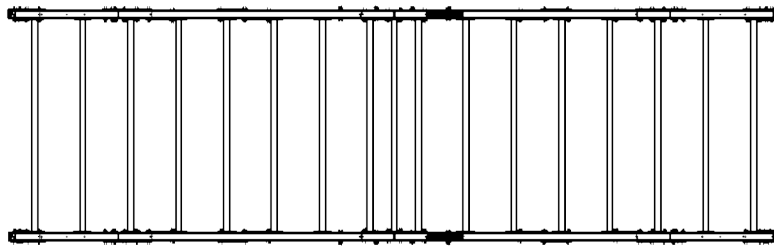

### Step 6

Install monkey bars between installed bridge sides. typical spacing on monkey bars is 16" spacing (two open holes between flanges). If installing monkey bars across the bottom of the bridge (as shown above) install monkey bars at the top of the bridge for bracing. Install logo onto center of bridge. Be sure to tighten all hardware.